

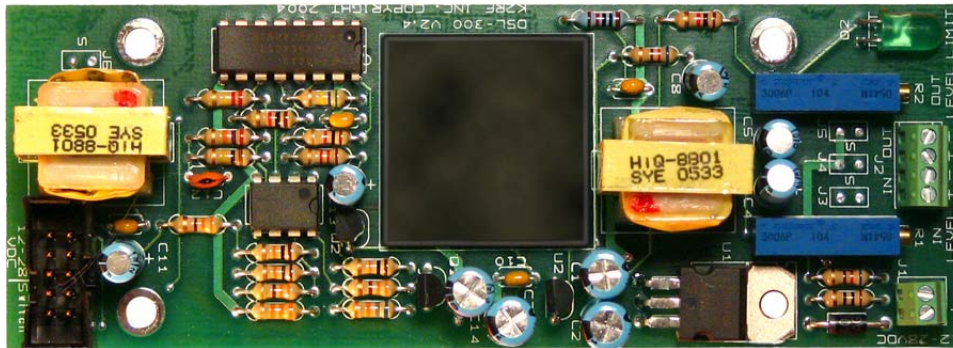

DSL-300 Dynamic Speech Limiter Installation and Calibration



General

The DSL-300 is a universal interface version of the famous K²RF DSL-100. It is capable of matching nearly any audio input or output need in any combination (balance or unbalanced / high or low impedance. This product is used to ensure that low level voice audio is increased to optimal levels with minimal increase in noise and high-level audio is decreased to optimal levels with no distortion or impact on the quality of the signal. This is accomplished through a unique design specific to K²RF that accurately tracks each syllable of speech rather than amplifying based on an averaging algorithm. The result is an increase in the quality and intelligibility of any received or transmitted audio.

If a version other than balanced 300 ohms input/output is desired, please contact K²RF for part numbers and pricing.

Installation

1. The DSL-300 is designed to operate from a DC input voltage in the range of 12vdc to 28vdc. Simply provide a well-filtered DC voltage within the range noted and attached to via the Green edge connector marked 12-18vdc. Please note the polarity of the DC voltage applied prior to turning on the power supply. A fused power line at 0.5 amps is strongly recommended.
2. Connection to the DSL-300 input is via the edge connector and is marked +/- IN 600 OHM BALANCED. Note the polarity and ensure that it matches the polarity of the device the DSL-300 is being attached to.
 - a. Attach the input to the DSL-300 from the output of the device currently being used to provide audio to your transmitter(s).

Preliminary Installation and Calibration

- b. Measure the audio levels at minimum, nominal, and maximum level of audio for your specific system(s). Write these levels down, as they will be needed later.
3. Connection to the DSL-300 output is via the edge connector and is marked +/- OUT 600 OHM BALANCED.

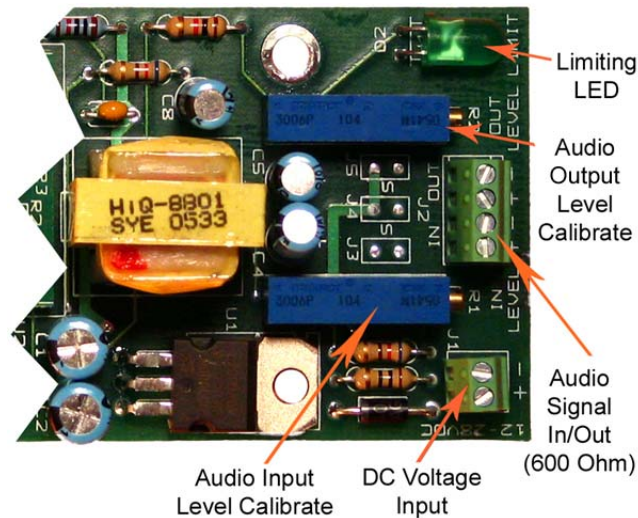

4. Ensure the DSL-300 is mounted securely via the 4, 6/32 standoff spacers. Be sure that the DSL-300 has no heat source or major RF source in close proximity to the circuitry. Confirm the Power provided is free from any ripple or RF as it will affect the overall quality of the audio and may result in a decrease in Signal to Noise.

Calibration

1. Equipment needed.
 - a. HP 4935A transmission test set or better
 - b. Service generator/monitor capable of generating the RF and audio necessary to generate the appropriate signal needed to simulate minimal, optimal, and maximum system performance. Also to confirm the proper operations of the system after calibration is completed.
 - c. DC volt meter
 - d. Small screwdriver (metal tip – non-metallic for adjustment of trim pots).
2. Attaching equipment
 - a. Ensure that you have measured your system audio to determine the desired minimal setting level, optimal setting level, and maximum setting level for the audio where the DSL-300 will be inserted. This step is critical and must be done prior to completing all subsequent steps. Write these values down. Be sure to use the same equipment as is used for the calibration to ensure consistency.

Preliminary Installation and Calibration

- b. Attach the Transmit signal from the HP 4935A to the input of the DSL-300. Observe the polarity. Be sure the HP4935A is set for 600 ohms.
- c. Attach the Receive from the HP 4935A to the output of the DSL-300. Observe the polarity. Be sure the HP4935A is set for 600 ohms.
- d. Attach the power supply. Observe the polarity and confirm prior to applying power to the DSL-300.
- e. Apply power to the DSL-300.
- f. Using the DVM confirm the input power is on and is operating between 12 and 28 volts DC. If not turn off the power supply and recalibrate the power supply or replace it with an appropriate supply.
- g. Set the HP4935A transmit frequency to 1004 Hz. And the output level to your minimal desired audio level.



- h. Measure the output level of the DSL-300 with the HP 4935A and note the level.

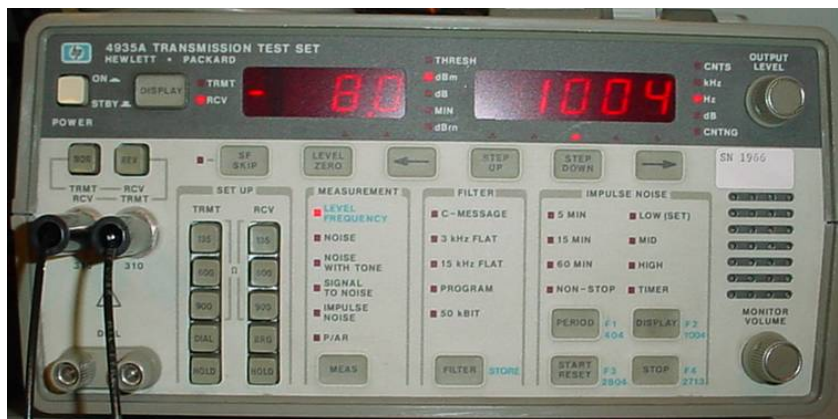

Preliminary Installation and Calibration

- i. While observing the green LED on the back of the DSL-300 adjust the INPUT LEVEL potentiometer CCW until the LED goes off. Then, adjust the INPUT LEVEL potentiometer CW just to the point where the LED goes on. This is the “Edge of Limiting”. Adjust the INPUT LEVEL potentiometer CW 1/4 turn beyond this point. Audio input levels below this set point will reduce linearly and levels above the current setting will be limited to the calibrated Output setting.
- j. While observing the OUTPUT level on the HP4935A, adjust the OUTPUT LEVEL potentiometer to the desired nominal level.
- k. While observing the LED, adjust the Transmit level on the HP 4935A to ensure that the minimum set point is as expected.
- l. Validate by adjusting the transmit level on the HP4935A 6 dB above the optimal output level and confirm it has does not change more than +/- 0.4dBm.
- m. Calibration is complete.

